

DESCRIPTION

ClimbTech 10,000-lbf / 44kN Removable Bolt Anchor.

A removable and reusable anchor designed to work in 25mm (1") drilled hole in concrete substrates.

RAF100N

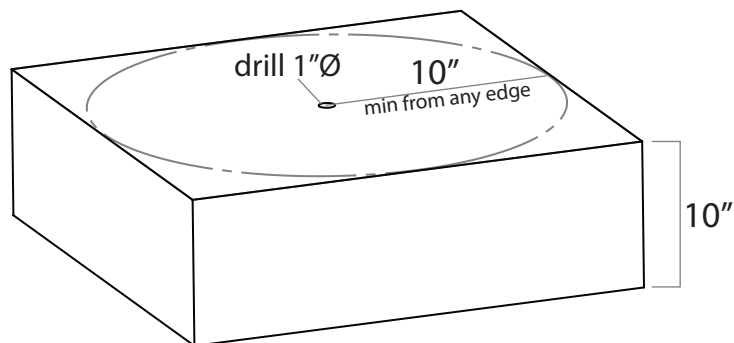
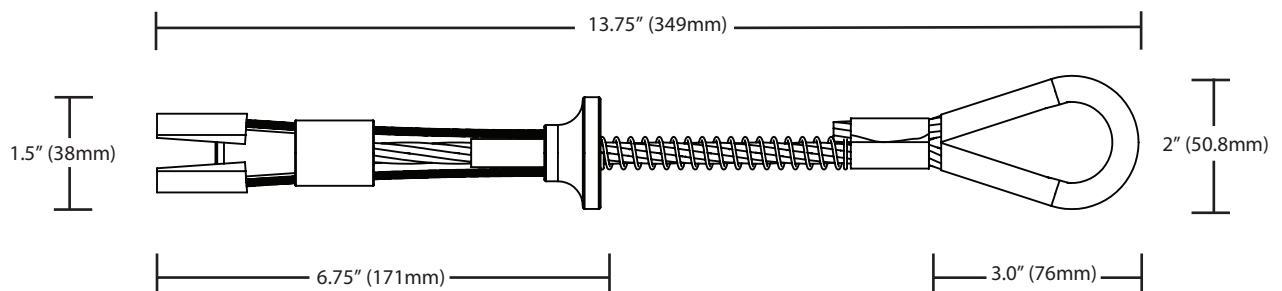

SPECIFICATIONS

- ▼ **UTS**
10,000-lbf / 44kN
- ▼ **Max User Weight**
310-lbs / 140kg
- ▼ **Working Load**
2000-lbs / 908kg

MATERIALS

- ▼ **Spoons**
Stainless Steel
- ▼ **Swage**
Zinc Plated Copper
- ▼ **Cone**
Stainless Steel
- ▼ **Thimble Loop**
Zinc Plated Steel
- ▼ **Cleaning Bushing**
Zinc Plated Steel
- ▼ **Spring**
Zinc Plated Steel
- ▼ **Stop Sleeve**
Stainless Steel
- ▼ **Trigger**
Aluminum
- ▼ **Main Cable**
Aircraft Cable
- ▼ **Return Wire**
Aircraft Cable

PRODUCT CONFIGURATIONS

| MODEL | APPLICATION | COLOR | LOADING | WEIGHT |
|---------|-------------|-------|-------------------|--------|
| RAF100N | Concrete | Blue | 10,000-lbf (44kN) | 467g |