

PERFORMANCE:

Static Tensile Strength: 10,000-lbf (44kN)

Maximum Capacity: One worker with max weight of 310-lbs (140kg) when used as a single point anchorage connector for personal fall arrest or restraint system

DIMENSIONS:

Weight: 1-lbs (453g)
Length: 13.75" (349mm)
Diameter: 1" (25mm)

REGULATORY COMPLIANCE:

ANSI Z359.1-2007, ANSI Z359.7-2011
 OSHA 1926.502, OSHA 1910.66,
 EN 795:1996 Class B CE0321

COMPONENT MATERIALS:

Aluminum: Trigger
Aircraft Cable: Main Cable, Activator Wire
Polyurethane: Loop Cover
Stainless Steel: Cone, Spoons, Stop Sleeve
Zinc Plated Steel: Spring
Zinc Plated Copper: Swage

DRILLING & INSTALLATION INSTRUCTIONS:

1. Drill a 1" (25mm) diameter hole at least 4.5" (114mm) deep. The drilled hole must be straight and perpendicular to the surface. Make sure the hole is of uniform diameter and free of peaks and valleys on the inner wall.
2. Blow hole clean with compressed air.
3. Always inspect the hole carefully when reusing a previously drilled hole.
4. When placing anchor, place your thumb inside the anchor loop and your first two fingers around the trigger. Squeeze fingers and thumb together till the trigger and spring fully compress.
5. Insert unit at least 4" (101mm) deep into hole and release the trigger. Do not force.
6. Set the unit with a slight tug on the anchor loop.
7. The stop sleeve must always be partially inserted into the hole.

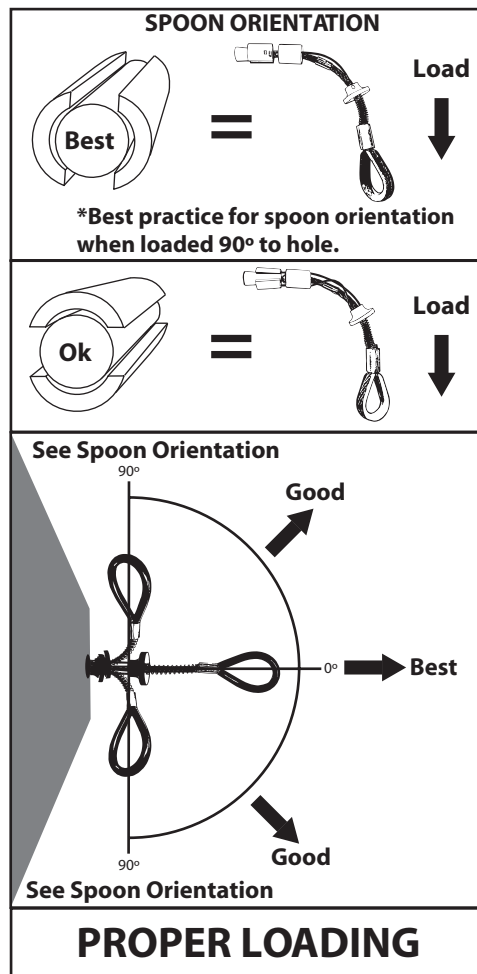
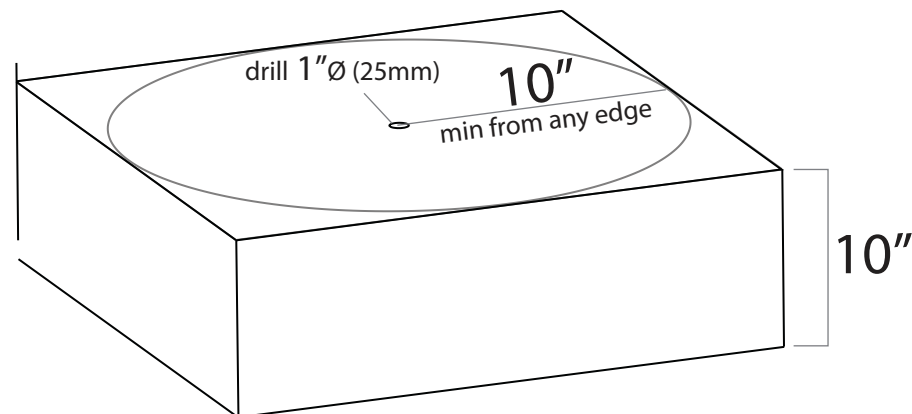

REMOVAL INSTRUCTIONS:

1. When removing anchor, place your thumb inside the anchor loop and your first two fingers around the trigger. Squeeze fingers and thumb together till the trigger and spring fully compress.
2. While squeezing the trigger pull the anchor out of the hole.
3. If the anchor becomes stuck, insert a punch, screwdriver or other object into the hole until it touches the top of the cleaning bushing.
4. Lightly tap with a hammer making sure the tool is touching the top of the cleaning bushing while squeezing the trigger (cleaning bushing should be easily visible at the edge of the hole).
5. If tool was required to remove the anchor, inspect thoroughly for damage after removal. If damage is found remove from service and destroy immediately.

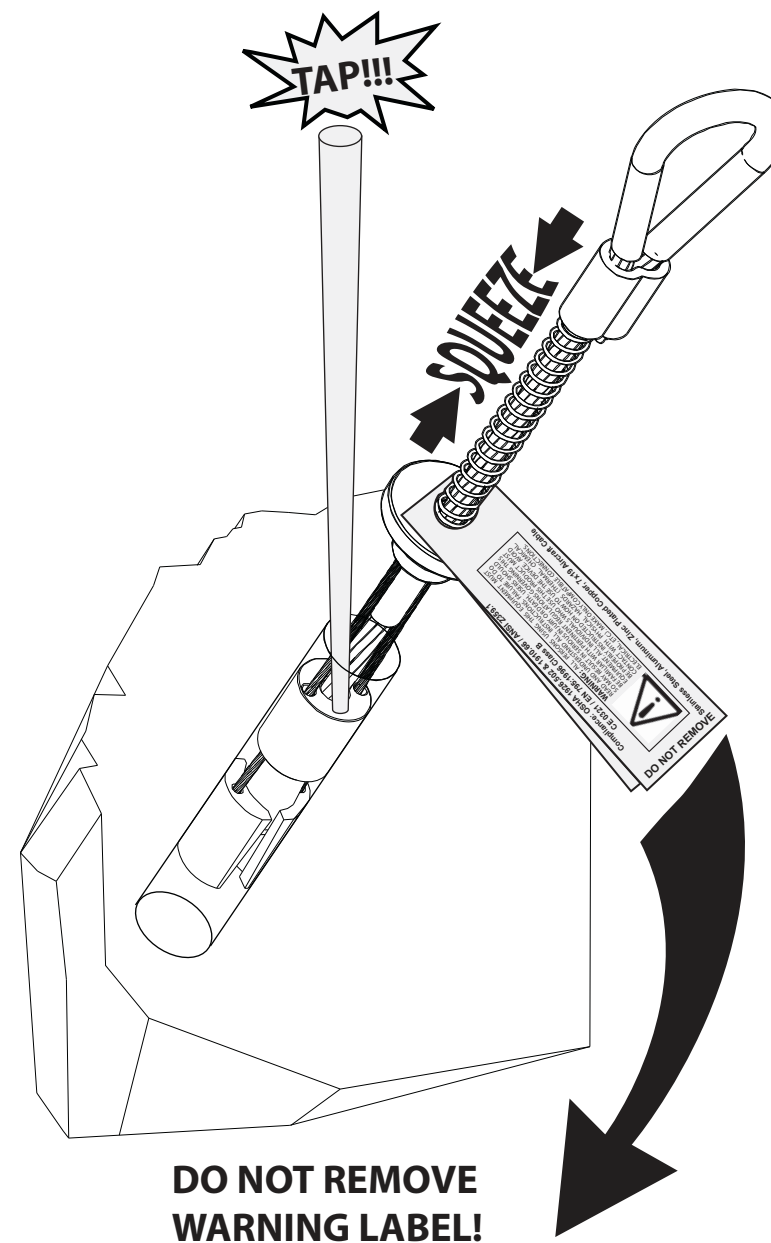

Compliance: OSHA 1926.502 & 1910.66 / ANSI Z359.1(07), ANSI Z359.7(11) EN 795:1996 Class B (CE0321)

WARNING: ALL PERSONS USING THIS EQUIPMENT MUST READ AND UNDERSTAND ALL INSTRUCTIONS. FAILURE TO DO SO MAY RESULT IN SERIOUS INJURY OR DEATH. USERS SHOULD BE FAMILIAR WITH PERTINENT REGULATIONS GOVERNING THIS EQUIPMENT. ALL INDIVIDUALS WHO USE THIS PRODUCT MUST BE PROPERLY INSTRUCTED ON HOW TO USE THE DEVICE. AVOID CONTACT WITH PHYSICAL HAZARDS (THERMAL, CHEMICAL, ELECTRICAL, ETC.). MAKE ONLY COMPATIBLE CONNECTIONS.

Stainless Steel, Aluminum, Zinc Plated Copper, 7x19 Aircraft Cable
 Part# US 7.357.363 B2 / US7.011.281 B2 / US 6.726.821 B2

Max Capacity 310lbs

CE 0321

MAX

1-(512) 308-6440

Removable Bolt Model: RAF 100N RB10-xxx / mm/yyyy INSPECT BEFORE USE

May be used as an anchor point for a leading edge restraint system. See optional anchor points below for example. The use of two anchors is not required for leading edge restraint systems unless otherwise specified by the manufacturer.

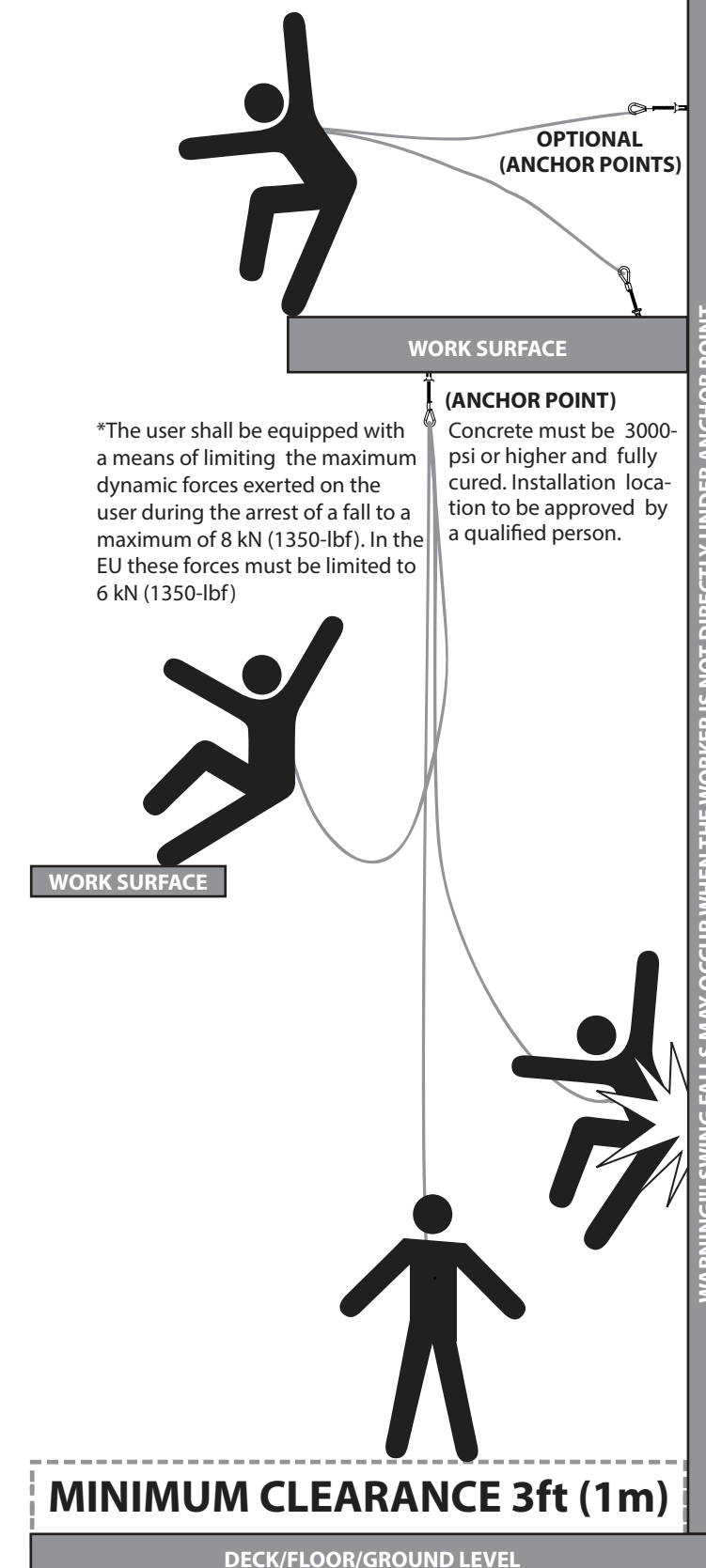

MINIMUM CLEARANCE 3ft (1m)

DECK/FLOOR/GROUND LEVEL

All products subjected to fall arresting forces should be removed from service immediately!